



Technical specification

Conforms: ANSI/AWWA C515 standard

Nominal pressure: 300PSI

Flange standard: ASME/ANSI B16.1 Class 125 or AMSE/ANSI B16.42 Class 150 or BS EN 1092-2 PN16 or GB/T9113.1

Mechanical standard: ANSI/AWWA 110 or ANSI/AWWA C153

Approvals: FM, UL, CUL, NSF/ANSI 61 & NSF/ANSI 372

Maximum working pressure: 300PSI (maximum testing pressure 600PSI) conforms to UL262, ULC/ORD C262-92, FM 1120/1130

Maximum working temperature 80°C/176°F

Coating details: epoxy coated interior and exterior by electrostatic spray or coating upon request

NPT plug on body with 1 operating nut

Certified lead-free by NSF/ANSI 61 & NSF/ANSI 372

Post flanged optional

| ITEM SIZE | L | Dn | D | c | n-d | H |
|-----------|-----|-------|-----|-------|--------|-----|
| 2" | 178 | 50 | 178 | 126.5 | 4-ø19 | 265 |
| 2-1/2" | 190 | 95 | 178 | 139.5 | 4-ø19 | 292 |
| 3" | 203 | 80 | 191 | 152.5 | 4-ø19 | 322 |
| 4" | 229 | 103 | 229 | 7.95 | 8-ø19 | 342 |
| 5" | 254 | 128.5 | 254 | 216 | 8-ø22 | 412 |
| 6" | 267 | 155 | 279 | 241.5 | 8-ø22 | 448 |
| 8" | 292 | 204 | 343 | 298.5 | 8-ø22 | 534 |
| 10" | 330 | 255 | 406 | 362 | 12-ø25 | 635 |
| 12" | 356 | 304 | 483 | 432 | 12-ø25 | 720 |

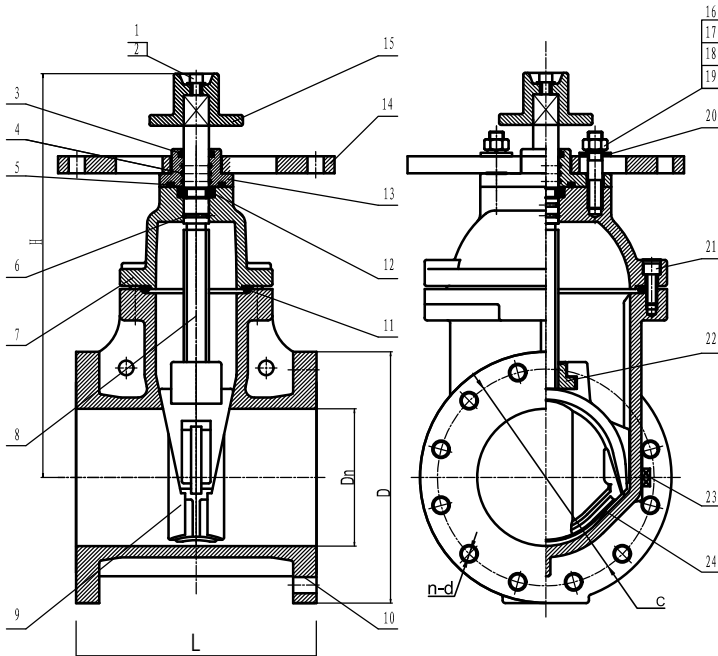

| No. | Part | Material Specification | Size |
|-----|---------------------|------------------------|------------|
| 1 | Flat Washer | S.S. 304 | ø12 |
| 2 | Inner Hexagon Screw | S.S. 304 | M12x30 |
| 3 | Sealing Gland | EPDM | |
| 4 | O-Ring | EPDM | ø35.5x3.55 |
| 5 | Sealing Ring | EPDM | ø60x7 |
| 6 | O-Ring | EPDM | ø30x3.55 |
| 7 | Bonnet | DI | |
| 8 | Stem | S.S. 304 | |
| 9 | Disc | DI + EPDM ASTM A429D | |
| 10 | Body | DI ASTM A536 | |
| 11 | Sealing Ring | EPDM | |
| 12 | Retaining Ring | C95400 | |
| 13 | Gland | DI | |
| 14 | Terminal Pad | DI | |
| 15 | Link Block | DI | |
| 16 | Nut | S.S. 304 | M16 |
| 17 | Studs | S.S. 304 | M16x85 |
| 18 | Sprint Washer | Steel | ø16 |
| 19 | Washer | Steel | ø16 |
| 20 | Washer | Steel | |
| 21 | Inner Hexagon Screw | S.S. 304 | M20x45 |
| 22 | Masterscrew | C95400 | |
| 23 | Plug | C95400 | |
| 24 | Skeleton | DI | |